



NOUVELLES FERMETURES INTERNATIONAL

# SOLUTIONS EN PORTES D'ENTRÉE

## ENTRANCE DOOR SOLUTIONS



nouvelle collection  
new collection

Portes d'entrée et intérieures, marquises, cloisons | Entrance and interior doors, canopies, partitions



# SOLUTIONS EN PORTES D'ENTRÉE

## ENTRANCE DOOR SOLUTIONS

**Chez NFI, chaque porte est conçue comme un élément essentiel de l'architecture, où performance, esthétique et durabilité s'unissent dans une solution complète. Nous développons une large gamme de portes d'entrée, intérieures et solutions complémentaires en aluminium, conçues pour répondre aux exigences du marché professionnel et aux besoins de chaque projet. Nos solutions se distinguent par la variété des configurations, gammes et typologies, allant des portes monobloc et pivotantes**

At NFI, each door is conceived as an essential architectural element, where performance, aesthetics, and durability come together in a complete solution. We develop a wide range of entrance doors, interior doors, and complementary aluminium solutions designed to meet the demands of the professional market and the needs of each project. Our solutions stand out for their wide variety of configurations, ranges, and typologies, from monoblock and pivot doors to interior

**aux portes intérieures, de service et systèmes vitrés. Chaque produit est développé avec des solutions constructives garantissant isolation thermique, étanchéité, sécurité et résistance à un usage intensif, assurant ainsi une performance constante dans le temps. La diversité des modèles et des finitions permet une grande liberté de personnalisation, s'intégrant facilement dans différents styles architecturaux, des plus contemporains aux plus minimalistes, toujours avec une attention particulière aux détails et à la qualité**

doors, service doors, and glazed systems. Each product is developed with construction solutions that ensure thermal insulation, watertightness, security, and resistance to intensive use, guaranteeing consistent performance over time. The diversity of models and finishes allows for great freedom of customization, integrating easily into different architectural styles, from the most contemporary to the most minimalist, always with attention to detail and material quality. Different panel thicknesses,



**des matériaux. Les différentes épaisseurs de panneau, solutions de fermeture, intégrations de vitrage et options constructives permettent d'adapter chaque porte au niveau d'exigence du projet, qu'il soit thermique, esthétique ou fonctionnel. Les solutions NFI sont conçues pour garantir un usage confortable et efficace, avec des systèmes d'ouverture fluides, une stabilité structurelle et des composants assurant fiabilité au quotidien. La compatibilité avec différentes configurations d'installation permet**

locking solutions, glass integrations, and construction options allow each door to be adapted to the project's level of requirement, whether thermal, aesthetic, or functional. NFI solutions are designed to ensure comfortable and efficient use, with smooth opening systems, structural stability, and components that guarantee reliability in daily use. Compatibility with different installation configurations allows easy integration on site, both in new builds and renovation projects.

**une intégration simple sur chantier, tant en construction neuve qu'en rénovation. L'innovation et la précision technique se reflètent dans chaque composant, renforcées par des laquages certifiés Qualicoat, Qualimarine et Qualanod, garantissant protection et durabilité même dans les conditions les plus exigeantes. Plus que des portes, nous proposons des solutions conçues pour valoriser les espaces, faciliter l'intégration sur chantier et répondre**

Innovation and technical precision are reflected in every component, reinforced by Qualicoat, Qualimarine, and Qualanod certified coatings, ensuring protection and durability even in the most demanding conditions. More than doors, we offer solutions designed to enhance spaces, facilitate on-site integration, and meet the expectations of each project with precision.

# Poignée

## Handle

### Poignée Standard

Standard handle



### Poignée encastré

Recessed handle



### Option bâton maréchal

Option bar pull handle

P 07.002



P 07.432



P 07.009



P 07.143



P 07.123



P 07.005



P 07.297



P 07.287



# Couleurs & finitions

## Colours & finishes

### Aluminium laqué

Powder-coated aluminium

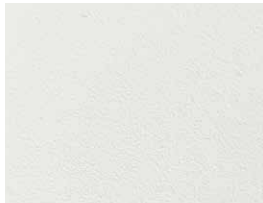

9016  
Sablé  
Textured



7016  
Sablé  
Textured



9005  
Sablé  
Textured



7036M  
Sablé métallique  
Metallic textured



7035  
Sablé  
Textured



2900  
Sablé  
Textured



2800  
Sablé  
Textured



2100  
Sablé  
Textured



1019M  
Sablé métallique  
Metallic textured



1015  
Sablé  
Textured



### Portes d'entrée Entrance doors

- 06 Portes pivotantes  
Pivot doors
- 08 Portes monobloc  
Monoblock doors
- 14 Porte vitrée  
Glass door
- 16 Porte de service  
Back door
- 17 Marquise  
Canopy



### Porte intérieure Interior door

- 18 Porte intérieure  
Interior door
- 20 Verrière en acier  
Steel glass partitions
- 22 Porte intérieure type atelier  
Atelier-style interior door



Porte d'entrée  
Entrance door

# PIVOTANT VITRÉE

2500x3500mm max.



Verre | Glass :  
33<sup>2</sup>, 14 GAZ, 44<sup>2</sup>  
33<sup>2</sup>, 14 GAZ, 55<sup>2</sup>  
44<sup>2</sup>, 14 GAZ, 55<sup>2</sup>

Portes  
pivotantes  
Pivot  
doors

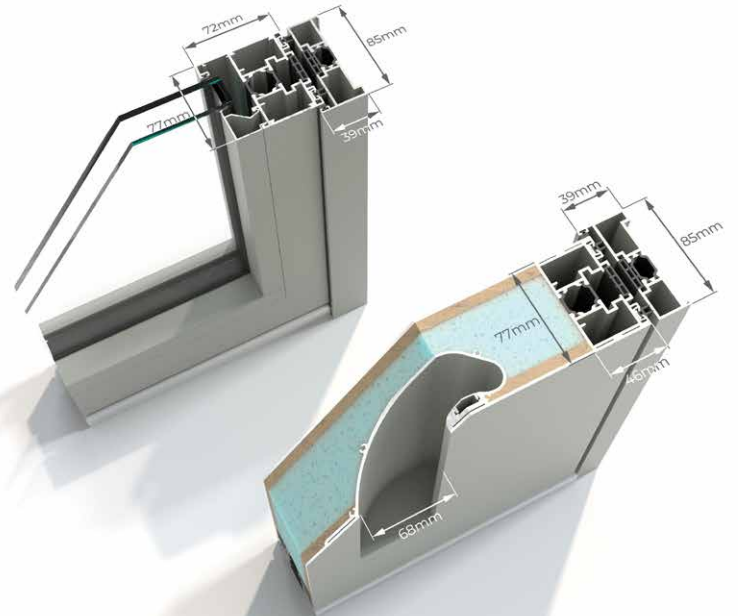

RAL standard sablé | Standard textured RAL:



Les portes pivotantes se distinguent par leur sophistication, leur design moderne et leur prestance, avec des dimensions généreuses qui les rendent idéales pour les entrées principales et les grandes ouvertures. L'ouverture sur axe pivotant, sans charnières visibles, garantit un mouvement fluide, stable et précis, particulièrement adapté aux espaces à grande hauteur sous plafond. Vous pouvez opter pour une porte en verre ou une porte avec panneau monobloc, en adaptant la solution au niveau de confidentialité, de luminosité et de performance souhaité. La porte pivotante en verre permet une plus grande entrée de lumière naturelle, avec différentes compositions de vitrage adaptées aux dimensions de la porte et aux exigences du projet. La porte Pivotante 80 avec panneau monobloc intègre un vantail de 77 mm, composé d'un noyau en polystyrène extrudé comprimé entre des plaques de contreplaqué bois PEFC et revêtu d'aluminium de 1,5 mm, garantissant une grande robustesse et une excellente isolation, avec un tirant encastré dans le panneau. La porte pivotante peut être configurée avec n'importe quel modèle des gammes Contemporaine et Moderne, qui offrent une grande diversité de solutions où surfaces usinées, applications en acier inoxydable et éléments en verre se combinent pour créer des compositions équilibrées, actuelles et facilement adaptables à différents styles architecturaux. Les deux solutions incluent une serrure automatique magnétique à trois points avec crochet et un seuil PMR anodisé avec rupture de pont thermique, assurant sécurité, confort et performance au quotidien.

Pivot doors stand out for their sophistication, modern design, and strong visual presence, with generous dimensions that make them ideal for main entrances and large openings. The pivot axis opening system, without visible hinges, ensures smooth, stable, and precise movement, particularly suited to spaces with high ceilings. You can choose between a glass door or a monoblock panel door, adapting the solution to the desired level of privacy, natural light, and performance. The glass pivot door allows greater natural light entry, integrating different glass compositions tailored to the door dimensions and project requirements. The Pivot Door 80 with monoblock panel features a 77 mm leaf, composed of an extruded polystyrene core compressed between PEFC plywood panels and clad with 1.5 mm aluminium, ensuring high robustness and excellent insulation, with a flush integrated handle. The pivot door can be configured with any model from the Contemporary and Modern ranges, offering a wide variety of solutions where machined surfaces, stainless steel applications, and glass elements combine to create balanced, modern compositions adaptable to different architectural styles. Both solutions include a three-point magnetic automatic lock with hook and an anodized threshold with thermal break (PMR), ensuring safety, comfort, and performance in daily use.

# PIVOTANT 80

2500x3500mm max.



Consulter les décors  
en page 10  
See decors on page 10

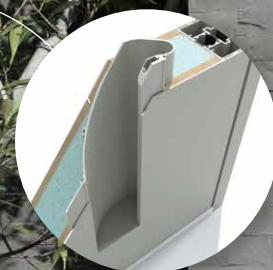

Poignée encastrée  
Recessed handle

# Portes monobloc

## Monoblock doors

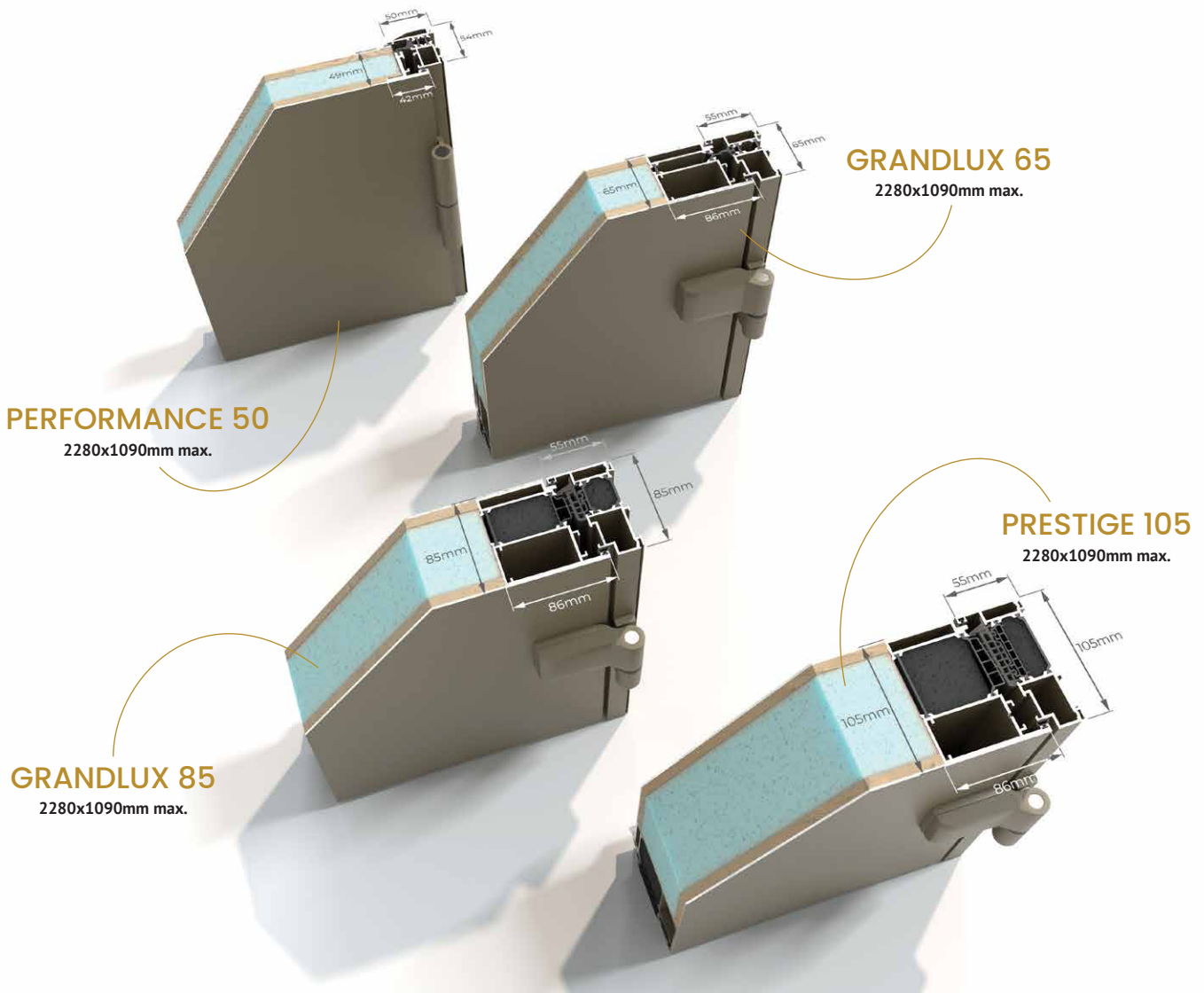

**PERFORMANCE 50**  
2280x1090mm max.

**GRANDLUX 65**  
2280x1090mm max.

**PRESTIGE 105**  
2280x1090mm max.

**GRANDLUX 85**  
2280x1090mm max.

RAL standard sablé | Standard textured RAL:

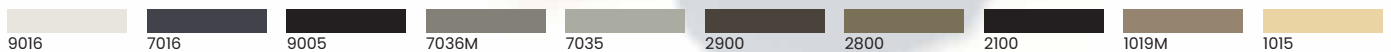

Les portes monobloc sont disponibles dans les gammes Contemporaine et Moderne, avec une grande diversité de modèles où surfaces usinées, applications en acier inoxydable et éléments en verre se combinent pour créer des compositions équilibrées, actuelles et facilement adaptables à différents styles architecturaux. Disponibles en épaisseurs de 50, 65, 85 et 105 mm, elles s'adaptent à différents niveaux d'exigence en matière d'isolation, de robustesse et de sécurité. Leur construction repose sur un panneau avec noyau en polystyrène extrudé, comprimé entre des plaques de contreplaqué bois PEFC et revêtu d'aluminium de 1,5 mm, garantissant stabilité structurelle et résistance à un usage intensif. La structure intègre un cadre fixe en aluminium avec rupture de pont thermique, un seuil PMR anodisé et un système de drainage, assurant des niveaux élevés d'étanchéité et de durabilité. Elle permet différentes solutions de fermeture, s'adaptant aux besoins de chaque projet.

Monoblock doors are available in the Contemporary and Modern ranges, offering a wide variety of models where machined surfaces, stainless steel applications, and glass elements combine to create balanced, modern compositions adaptable to different architectural styles. Available in thicknesses of 50, 65, 85, and 105 mm, they meet different levels of requirements in terms of insulation, robustness, and security. Their construction is based on a panel with an extruded polystyrene core, compressed between PEFC plywood boards and clad in 1.5 mm aluminium, ensuring structural stability and resistance to intensive use. The structure includes a fixed aluminium frame with thermal break, an anodized PMR threshold, and a drainage system, ensuring high levels of watertightness and durability. It allows for different locking solutions to meet the needs of each project.

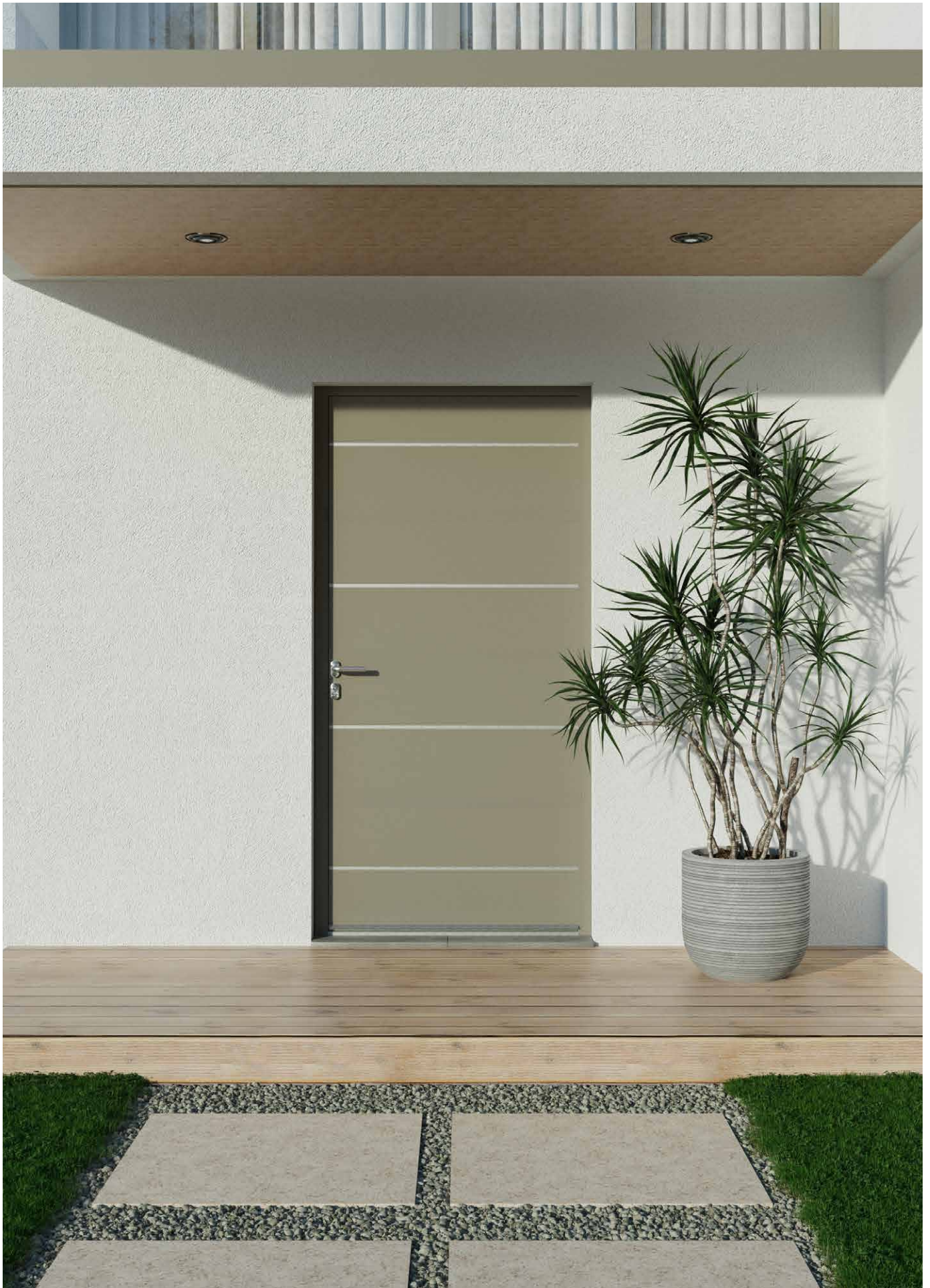

# Portes monobloc

Monoblock doors

PIVOTANT 80, PRESTIGE 105,  
GRANDLUX 65 & 85, PERFORMANCE 50

Contemporaine



ANDROS



ASINARA ALUNOX



AÇORES ALUNOX



BOA VISTA



BRAVA



CABRERA



CABRERA ALUNOX



CAPRAIA



CAPRERA ALUNOX

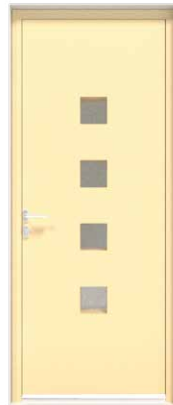

CAPRI



CORFOU



CORFOU ALUNOX



CORSE



CORSE ALUNOX



CUNDA

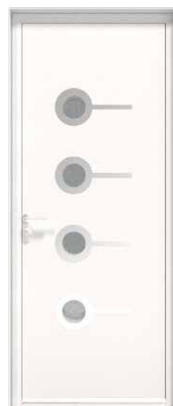

CUNDA ALUNOX



DIA ALUNOX



FOGO



GOZO ALUNOX



IBIZA



KASSOS ALUNOX



LAMPEDUSA



LEUCADE ALUNOX



LIPARI ALUNOX



LISSE



LUNDY



MADEIRA ALUNOX



MAIO



MALTE ALUNOX



MINDELO



MOLAT

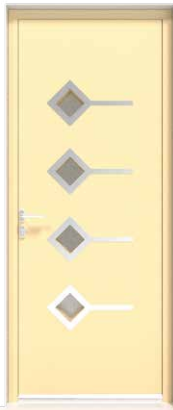

MOLAT ALUNOX



MONTECRISTO



PAXOS



PAXOS ALUNOX



PIANOSA ALUNOX



RHODES ALUNOX



RINIA



RINIA ALUNOX



SALINA



SAMOS



SANTA LUZIA



SANTO ANTÃO



SANTORINI



SICILE



SICILE ALUNOX



SILBA ALUNOX



SÃO NICOLAU



SÃO VINCENTE



TILOS ALUNOX



TILOS ALUNOX PLUS



VIR ALUNOX



VULCANO ALUNOX



ZANTE ALUNOX 1



ZANTE ALUNOX 2



ZANTE ALUNOX 3



BAAR



BALE



BERGÜN



BULLE



CATANE



DORTMUND



EMMEN



ESSEN



FLORENCIA



FRANCFORT



GENEVE



KALMAR



KYOTO



LAUSANNE



LEIPZIG



LUCERNE



MEYRIN



MILANO



NAPOLES



ONEX



OSLO



PALERMO



PULLY



REMIÀ



ROMA



SALZBOURG



SAPPORO



SENDAI



SIENNA



TOKYO



TORINO

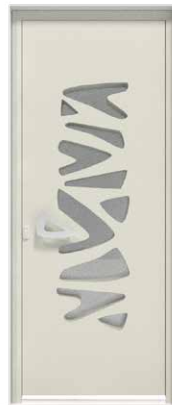

TREVES



USHUAIA



VENEZIA



# Porte vitrée

## Glass door

RAL standard sablé | Standard textured RAL:

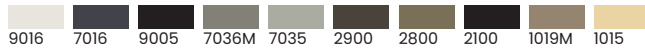

La porte Consensus en verre intègre un vitrage texturé, avec plusieurs options de sablage artistique apportant confidentialité et identité esthétique. Disponible avec profil Onduline ou Architect, elle s'adapte aux différentes exigences de projet. La structure intègre un cadre fixe en aluminium avec rupture de pont thermique, un seuil PMR anodisé et un système de drainage, assurant des niveaux élevés d'étanchéité et de durabilité. Elle permet différentes solutions de fermeture garantissant la sécurité.

The Consensus glass door features textured glass, with various artistic frosted options that provide privacy and aesthetic identity. Available with Onduline or Architect profiles, it adapts to different project requirements. The structure includes a fixed aluminium frame with thermal break, an anodized PMR threshold, and a drainage system, ensuring high levels of watertightness and durability. It allows for different locking solutions, ensuring security.

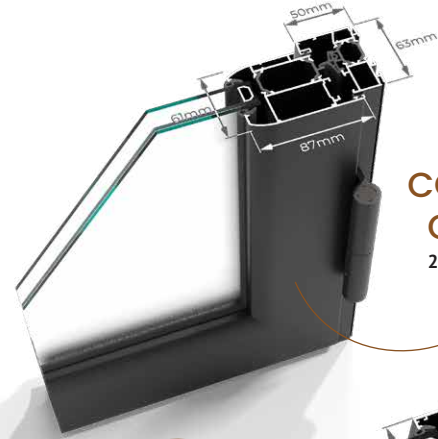

**CONSENSUS  
ONDULINE**  
2280x1090mm max.

**CONSENSUS  
ARCHITECT**  
2280x1090mm max.

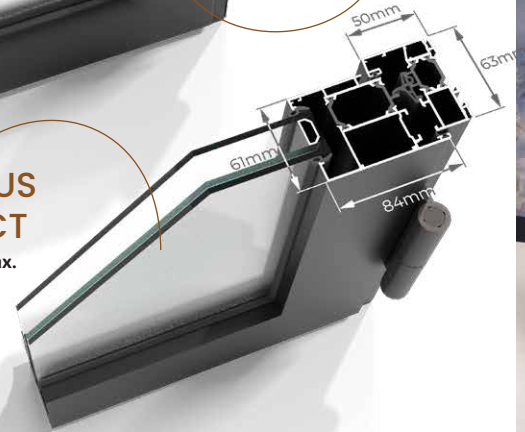

**ONDULINE:**

4 FE, 12 GAZ, 44<sup>2</sup> Sablé WGE  
4 FE, 12 GAZ, 44<sup>2</sup> Sandblasted WGE

**ARCHITECT :**

4 FE, 16 GAZ, 44<sup>2</sup> Sablé WGE  
4 FE, 16 GAZ, 44<sup>2</sup> Sandblasted WGE

SYROS



AÇORES

ASINARA

CABRERA  
INV

CABRERA  
NORM

CAPRERA

CORFOU  
INV

CORFOU  
NORM

CORSE  
INV



CORSE  
NORM

DIA

LEUCADE

LIPARI  
INV

LIPARI  
NORM

MADEIRA

MALTE

MILOS



MOLAT  
INV

MOLAT  
NORM

PAXOS  
INV

PAXOS  
NORM

PIANOSA  
INV

PIANOSA  
NORM

RINIA  
INV

RINIA  
NORM



SICILE  
INV

SICILE  
NORM

SILBA

TILOS

TINOS

VULCANO

ZANTE  
INV

ZANTE  
NORM



PSP



PSO

# Porte de service Back door

RAL standard sablé | Standard textured RAL:

9016	7016	9005	7036M	7035
2900	2800	2100	1019M	1015

La porte de service est disponible avec profil Série Froide, Onduline ou Architect, s'adaptant à différents besoins d'utilisation. La version Série Froide est composée de panneaux sandwich de 30 mm, tandis que les versions Onduline et Architect intègrent des panneaux de 30 mm en polystyrène extrudé (XPS), garantissant de meilleures performances thermiques. Elle peut également intégrer un vitrage pour des visuels (oculus). La structure comprend un cadre fixe en aluminium avec rupture de pont thermique, un seuil PMR anodisé et un système de drainage, assurant des niveaux élevés d'étanchéité et de durabilité. Elle permet différentes solutions de fermeture garantissant la sécurité.

The Back door is available with Cold series, Onduline, or Architect profiles, adapting to different usage needs. The Cold series version is composed of 30 mm sandwich panels, while the Onduline and Architect versions incorporate 30 mm extruded polystyrene (XPS) panels, ensuring improved thermal performance. It can also integrate glass for vision panels. The structure includes a fixed aluminium frame with thermal break, an anodized PMR threshold, and a drainage system, ensuring high levels of watertightness and durability. It allows for different locking solutions, ensuring security.

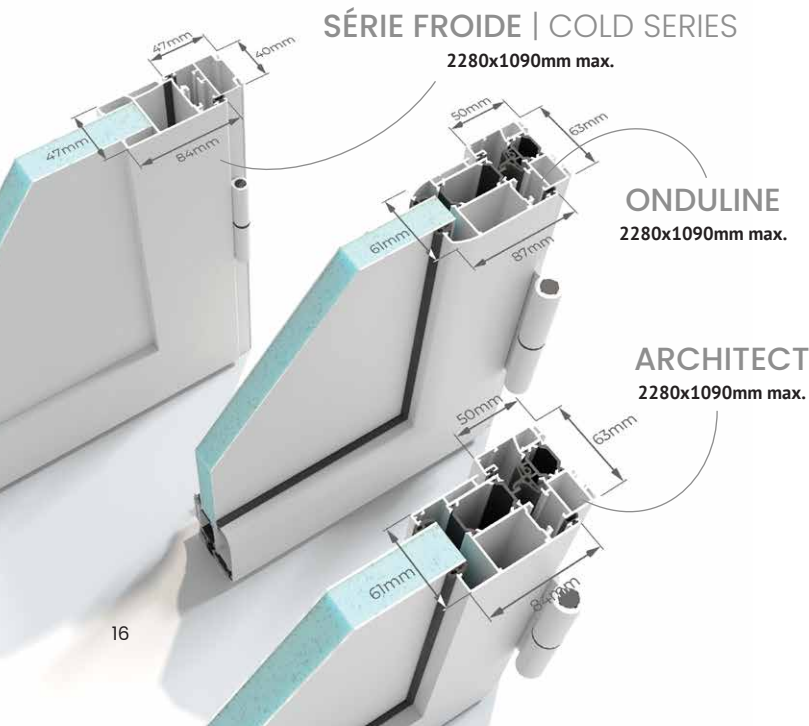

RAL standard sablé | Standard textured RAL:

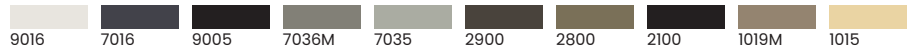

# Marquise Canopy

Les marquises NFI sont conçues pour protéger l'entrée, en combinant fonctionnalité, résistance et intégration esthétique avec la façade. Disponibles en différents modèles et configurations, elles peuvent intégrer du verre ou du polycarbonate traité anti-UV, avec des structures en aluminium thermolaqué. La construction comprend des profils robustes, des systèmes de fixation sécurisés et des solutions de drainage garantissant durabilité et stabilité. Disponibles en options standard ou sur mesure pour s'adapter à chaque projet.

NFI canopies are designed to protect entrances, combining functionality, durability, and aesthetic integration with the façade. Available in different models and configurations, they can incorporate glass or UV-treated polycarbonate, with powder-coated aluminium structures. The construction includes robust profiles, secure fixing systems, and drainage solutions that ensure durability and stability. Available in standard or custom-made options to suit each project.

CONSENSUS



SCHMETTERLING



SKYDOOR



GRANDLUX



Sur Mesure | Custom size:  
2500x1050mm max.

## BRISE SOLAIRE FIXE

6000x1010mm max.





ST. LUCIA



NEVIS



CURACAO



BAHAMAS



BARBADOS



SAN SALVADOR



ARUBA



ABACO



ANGUILLA



ANTIGUA

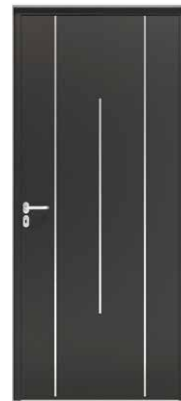

ST. VINCENT



TORTOLA



BERMUDA



CUBA



DOMINICA



JAMAICA



GRENADA



HAITI



CAYMAN



MARTINIQUE



MONTSERRAT



PUERTO RICO



ST. MARTIN



REDONDA

# Porte intérieure

## Interior door

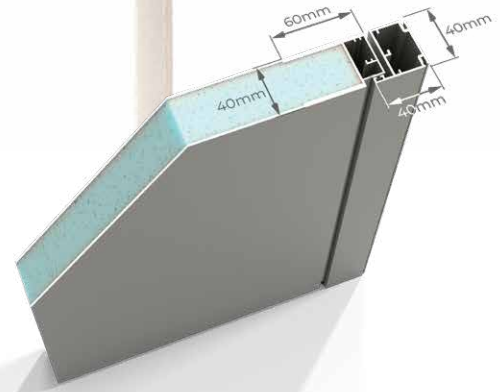
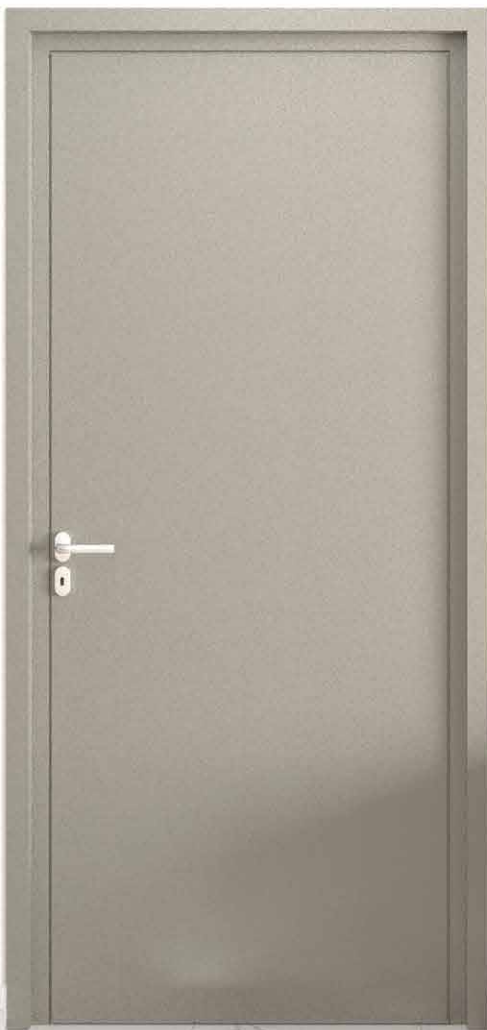

RAL standard sablé | Standard textured RAL:

9016	7016	9005	7036M	7035
2900	2800	2100	1019M	1015

Les portes intérieures NFI s'intègrent dans la gamme Contemporaine, présentant une large diversité de modèles où surfaces usinées et applications en acier inoxydable se combinent pour créer des compositions équilibrées, actuelles et adaptables à différents styles architecturaux. Disponibles en version standard ou sur mesure, elles sont construites avec des panneaux de 40 mm en polystyrène extrudé (XPS), garantissant légèreté et résistance à l'usage quotidien. Elles permettent également l'intégration de solutions coulissantes encastrées dans la cloison et incluent une poignée PMR en acier inoxydable.

NFI interior doors are part of the Contemporary range, offering a wide variety of models where machined surfaces and stainless steel applications combine to create balanced, modern compositions adaptable to different architectural styles. Available in standard or made-to-measure versions, they are built with 40 mm extruded polystyrene (XPS) panels, ensuring lightness and durability for everyday use. They also allow the integration of pocket sliding solutions within the wall and include a stainless steel PMR handle.

TRINIDAD



**Verre | Glass :**  
Standard: verre trempé de 4 mm  
Sur mesure : verre feuilleté 33'  
Standard: 4 mm tempered glass  
Custom-made: laminated glass 33'

# Verrière en acier

## Steel glass partitions

RAL standard sablé | Standard textured RAL:

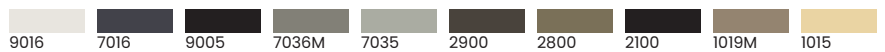

Les cloisons vitrées en acier sont des solutions conçues pour diviser les espaces intérieurs tout en préservant l'apport de lumière et la continuité visuelle. Disponibles en versions fenêtre fixe ou ouvrante, ainsi qu'en porte battante ou coulissante, elles s'adaptent à différentes configurations et exigences de projet. Avec un profil de 30x30 mm, elles peuvent intégrer un vitrage feuilleté 33' sur mesure ou un vitrage trempé de 4 mm en dimensions standard, garantissant résistance et fonctionnalité au quotidien, avec une esthétique contemporaine et industrielle.

Steel glass partitions are glazed solutions designed to divide interior spaces while maintaining natural light flow and visual continuity. Available as fixed or opening windows, as well as hinged or sliding doors, they adapt to different configurations and project requirements. With a 30x30 mm profile, they can incorporate custom laminated glass 33' or standard 4 mm tempered glass, ensuring strength and functionality for daily use, with a contemporary and industrial aesthetic.



VERRIÈRE FIXE  
FIXED GLAZING

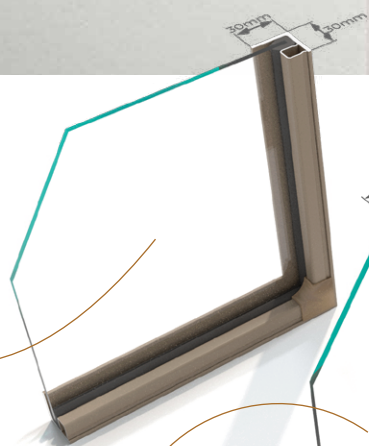

ENSEMBLE FIXE  
FIXED SET

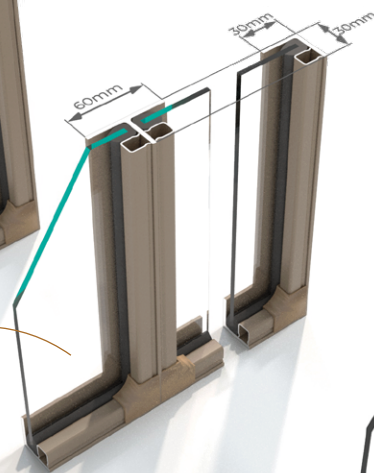

VERRIÈRE  
OUVRANTE  
WINGED  
GLAZING



# Porte intérieure type atelier Atelier-style interior door

## Cloison Fixe Fixed Partition

Standard: 830x2470 mm  
Sur mesure | Custom made: 1030x2500mm max.



Verre trempé  
de 4 mm  
Laminated  
glass 33<sup>1</sup>



## Porte coulissante Sliding door

Standard: 830x2040 mm  
Sur mesure | Custom made: 1030x2200mm max.



## Porte battante Winged door

Standard: 830x2040 mm  
Sur mesure | Custom made: 1030x2200mm max.



## Porte coulissante dressing Sliding door for dressing closet

Sur mesure | Custom made: 2060x2500mm max.



## Cloison de douche Partition for bath

Sur mesure | Custom made: 1030x2500mm max.



RAL standard sablé | Standard textured RAL:



La porte en aluminium type Atelier associe un design minimaliste à une construction légère et fonctionnelle, idéale pour diviser les espaces intérieurs tout en laissant passer la lumière. Elle intègre un profil de 40x20 mm et un vitrage trempé de 4 mm, garantissant stabilité et sécurité à l'usage quotidien ainsi qu'une intégration discrète et harmonieuse dans l'espace. Disponible en versions coulissante, battante ou fixe, elle s'adapte à différentes configurations. En version battante, la porte est équipée d'une poignée en acier inoxydable. Dans le système coulissant, elle ne dispose pas de système de fermeture, privilégiant la simplicité d'utilisation et la fluidité entre les espaces.

The Atelier-style aluminium door combines a minimalist design with a lightweight and functional construction, ideal for dividing interior spaces while allowing light to pass through. It features a 40x20 mm profile and 4 mm tempered glass, ensuring stability and safety in daily use, as well as discreet and harmonious integration within the space. Available in sliding, hinged, or fixed versions, it adapts to different configurations. In the hinged version, the door is equipped with a stainless steel handle. In the sliding system, it does not include a locking system, prioritizing ease of use and fluidity between spaces.



NOUVELLES FERMETURES INTERNATIONAL

Rua da Braziela, nº51 Fradelos 4760-564  
Vila Nova de Famalicão, Portugal

**Tel.:** (00 351) 252 412 734  
**Email:** [relationclient@nfi.pt](mailto:relationclient@nfi.pt)  
**Online:** [www.nfi.pt](http://www.nfi.pt)

